

TECHNICAL SPECS

Schäffer Model 2428

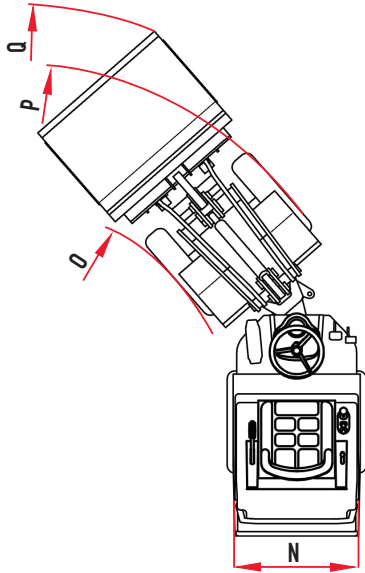

	DIMENSIONS	2428
A	Wheelbase	5 ft 0.2 in
B	Chassis length	9 ft 11.3 in
C	Overall length with standard bucket	12 ft 4.1 in
D	Digging depth	4.3 in
E	Max. working height	9 ft 8.5 in
F	Max. bucket pivot height	7 ft 6.6 in
G	Loading height with pallet fork	7 ft 0.6 in
H	Max. dumping height	4 ft 9.1 in
I	Front end height	4 ft 5.5 in
J	Dumping depth	18.5 in
K	Seat height	3 ft 5.5 in
L	Overhead guard height	6 ft 10.3 in
N	Overall width	35 - 49.2 in
O	Inner turning radius	2 ft 9.9 in
P	Outer turning radius	5 ft 9.1 in
Q	Outer radius with standard bucket	6 ft 10.9 in

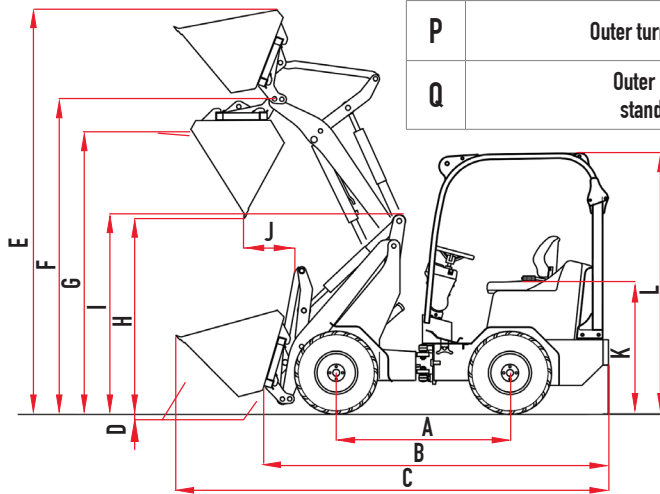

	TECHNICAL DATA	2428
Engine		3 Cyl. KUBOTA D1105, 25 hp (18.5 kW)
Traction hydraulics		Hydrostatic-automotive
Service braking system		Hydrostatic and mechanical drum brake
Parking brake		Mechanical drum brake
Working hydraulics output/pressure		Delivery rate: 11.1 GPM Operating pressure: 2,900 psi
Steering		Fully hydraulic articulated/swivel steering
Operating weight		4,012 lbs
Lifting capacity		3,748 lbs
Tipping load, straight ¹		Pallet fork 2,306 lbs Bucket 2,685 lbs
Tipping load, articulated ¹		Pallet fork 1,874 lbs Bucket 2,249 lbs
Payload		Pallet fork, even ground ² 1,499 lbs Pallet fork, uneven ground ² 1,124 lbs Bucket ³ 1,124 lbs
Axles		Original Schäffer axles, 5-hole rim
Speed		9.3 mph
Electric system		Operating voltage: 12 V
Fill quantities		Fuel: 6.1 gal Hydraulic oil: 7.9 gal
Sound pressure level LpA		84 dB(A)

¹ acc. to ISO 8313 ² acc. to EN 474-3 ³ acc. to ISO 14397-1

Tire dimensions and additional equipment can change the operating weight, tipping load, and payload.

Wheel Options (Standard tire option highlighted in yellow)

DIMENSION	LOADER WIDTH (in)*	TREAD OPTIONS
27x8.50-15	37 (42.5)**	SKD
7.00-12	35	AW
27x10.50-15	42.1	SKD
26x12.00-12	43.3 - 49.2	SKD, AS Farmer, Multi Trac, Allground



SKD



AS FARMER



ALLGROUND



MULTI TRAC



AW

*Measurements vary based on rim offset configurations.
**Measurements in brackets for width with turned wheels.